



A distributed middleware infrastructure for personalized services

Marios D. Dikaiakos^{a,*}, Demetris Zeinalipour-Yazti^b

^aDepartment of Computer Science, University of Cyprus, Kallipoleos 75, P.O. Box 20537, Nicosia 1678, Cyprus

^bDepartment of Computer Science, University of California, Riverside, CA, USA

Received 24 November 2003; revised 15 April 2004; accepted 16 April 2004

Available online 28 May 2004

Abstract

In this paper, we present an overview of extensible Retrieval, Annotation and Caching Engine (eRACE), a modular and distributed intermediary infrastructure that collects information from heterogeneous Internet sources according to registered profiles or end-user requests. Collected information is stored for filtering, transformation, aggregation, and subsequent personalized or wide-area dissemination on the wireline or wireless-Internet. We study the architecture and implementation of the main module of eRACE, an HTTP proxy named *WebRACE*. *WebRACE* consists of a high-performance, distributed and multithreaded Web crawler, a multithreaded filtering processor and an Object Cache. We discuss the implementation of *WebRACE* in Java, describe a number of performance optimizations, and present its performance assessment.

© 2004 Elsevier B.V. All rights reserved.

Keywords: Intermediaries; Personalization; Crawling

1. Introduction

The rapid expansion of the Web, and the developments in mobile-device and wireless-Internet technologies have resulted to a large heterogeneity of client devices currently used for accessing Internet services. Furthermore, they have raised the capacity mismatch between clients and Internet servers. To cope with these trends, software infrastructures for Internet services have to: (i) support seamless access from a variety of devices; (ii) customize content according to the requirements and limitations of different terminal devices; (iii) support both synchronous (on-demand) and asynchronous modes of interaction with users, thus coping with frequent disconnections of wireless access and user mobility; (iv) optimize the amount of useful content that reaches users through client devices with limited resources and restricted interfaces, by enabling service personalization, localization and filtering of information; and (v) guarantee high availability and robustness, as well as incremental performance and capacity scalability with an expanding user base.

Possible approaches for coping with these requirements are the so-called end-to-end solutions, where origin servers adapt their content on-the-fly, taking into account consolidated user profiles [42] or the terminal device and network connection involved in a user session [34]. For an end-to-end approach to work properly, however, adaptation software has to be inserted at each origin server. Consequently, software updates have to be propagated to all origin servers whenever new terminal devices and content-encoding protocols emerge. Moreover, on-the-fly adaptation of content can be very time-consuming, leading to a deterioration of user experience [20].

An alternative approach for providing personalization, content customization, ubiquity and mobility, is the employment of proxies with a functionality significantly extended over what is found in traditional proxies for the wireline or wireless Web [20]. Given the high-performance requirements for high throughput, 24 × 7 availability, and performance scalability of next-generation Internet services [12,39], however, centralized proxies are expected to face performance problems as well, thus necessitating the distribution of their computation, storage and complexity into the networking infrastructure [20]. In such a case, a number of distributed, programmable and possibly mobile *intermediary servers* would be deployed throughout

* Corresponding author. Tel.: +357-22892700; fax: +357-22892701.

E-mail addresses: mdd@ucy.ac.cy (M.D. Dikaiakos), csyiazti@cs.ucr.edu (D. Zeinalipour-Yazti).

the network. These servers would mediate between primary information sources and various client systems, providing performance scalability, better sharing of resources, higher cost efficiency, and a streamlining of new service provision [11].

The focus of our work is on the development of extensible Retrieval, Annotation and Caching Engine (eRACE), an *intermediary* infrastructure with enhanced functionality and distributed architecture, to support the development and deployment of personalized services and the provision of ubiquitous access thereof. In this paper, we present the design principles and architecture of eRACE. Furthermore, we describe the design, implementation and performance assessment of *WebRACE*, which is an eRACE-proxy dealing with collecting, filtering and caching content from the World-Wide Web, according to personal and service profiles. WebRACE consists of a multithreaded crawler, a multithreaded filtering engine, and an Object Cache. The remaining of this paper is organized as follows: Section 2 presents an overview of the eRACE architecture. Section 3 describes the main challenges behind WebRACE design and implementation. Sections 4–6 describe the main components of WebRACE: the Mini-Crawler, the Object Cache and the Annotation Engine (AE). Section 7 presents our experimentation and performance assessment of WebRACE. Furthermore, it presents the performance enhancements that we achieve by caching to cache the crawling state in the Object Cache, and by distributing the crawler to a network of workstations. Section 8 presents an overview of recent related work. We provide our conclusions in Section 9.

2. The architecture of eRACE

2.1. Overview and goals

The *extensible Retrieval, Annotation and Caching Engine (eRACE)* is a middleware infrastructure designed to support the development and deployment of *intermediaries* on Internet. Intermediaries are ‘software programs or agents that meaningfully transform information as it flows from one computer to another’ [9,37], and represent a useful abstraction for describing and developing personalized proxies, mobile services, etc.

eRACE is a modular, configurable, and distributed proxy infrastructure that collects information from heterogeneous Internet sources and protocols according to *eRACE profiles* registered within the infrastructure, and end-user requests. Collected information is stored in the software cache for further processing, personalized dissemination to subscribed users, and wide-area dissemination on the wireline or wireless-Internet.

eRACE supports personalization by enabling the registration, maintenance and management of personal profiles representing the interests of individual users. Furthermore,

its structure allows the easy customization of service provision according to parameters, such as information-access modes (pull or push), client-proxy communication (wireline or wireless; e-mail, HTTP, WAP), and client-device capabilities (PC, PDA, mobile phone, thin clients). Ubiquitous service-provision is supported by eRACE; thanks to the decoupling of information retrieval, storage and filtering, from content publishing and distribution. The eRACE infrastructure can also easily incorporate mechanisms for providing subscribed users with differentiated service-levels at the middleware level. Finally, the design of eRACE is tuned for providing performance scalability, which is an important consideration given the expanding numbers of WWW users, the huge increase of information sources available on the Web, and the need to provide robust services.

Key design and implementation decisions made to accomplish these goals are described below:

1. The information architecture of eRACE is defined in terms of meta-data that represent user account and connection information, user and service profiles, state information of eRACE modules and information exchanges taking place between them. Specifications are defined as XML Document Type Definitions (DTDs) [50]. We chose XML because it is simple, self-descriptive, and extensible. Hence, we can easily extend our descriptions to incorporate new services, terminal devices, and QoS policies. Furthermore, we can re-use existing modules and APIs that process XML data. Central to this set of meta-data is the ‘eRACE profile’ and the ‘eRACE annotation.’ The *eRACE profile* is a concise XML description of the operations and transformations that eRACE modules are expected to perform upon heterogeneous Internet sources: information gathering, filtering and caching of retrieved content, transcoding, dissemination, etc. The eRACE-profile DTD is general and expressive so as to represent: (i) personal interests of subscribers, thus supporting the deployment of personalized services over the Web; (ii) generic services that can be deployed on wide-area networks, such as notification systems, portals, mobile services, etc. The results of profile-driven, filtering operations performed upon gathered content are encoded in XML and named *eRACE Annotations* or *Annotation Cache Informations (ACIs)*.
2. Data sharing between modules of the eRACE infrastructure is done through messages that transport XML-encoded information and events. Therefore, we can easily decouple and isolate modules from each other and distribute them physically across machine boundaries at configuration or run-time. Furthermore, modules with stringent performance requirements are multithreaded and employ distributed data-structures [29], to allow the exploitation of parallel execution on shared-memory multiprocessor systems and networks of workstations.

3. eRACE translates user requests and eRACE profiles into ‘eRACE requests,’ encoded in XML and tagged with QoS information. These requests are scheduled for execution by an eRACE scheduler, which can implement different scheduling policies based on QoS tags. The explicit maintenance of XML-encoded information regarding pending requests and content scheduled for dissemination, makes it easy to keep track of the system’s run-time behavior, to compare alternative scheduling algorithms, to implement load-balancing techniques for sustaining high-availability during high loads, and to apply QoS policies with different service-levels.
4. eRACE is implemented with Java [28]. Java was chosen for a variety of reasons. Its object-oriented design enhances the software development process, supports rapid prototyping and enables the re-use and easy integration of existing modules. Java class libraries provide support for key features of eRACE: platform independence, multithreading, network programming, high-level programming of distributed applications, string processing, code mobility, compression, etc. Our choice of Java, however, came with a certain risk-factor that arose from known performance problems of this platform and its run-time environment. Performance and robustness are issues of critical importance for systems like eRACE, which must perform as a server, run continuously and sustain high loads at short periods of time.
5. Support for mobility and disconnected operations of Proxy and Content-Distribution agents will be provided by Mitsubishi’s Concordia Mobile Agent platform

[35,36]. For that matter, we have conducted a number of studies to assess the performance and robustness of this platform, with encouraging results [23,48]. Furthermore, we implemented two earlier prototypes of eRACE [21,51] with Concordia; mobile agents were used to implement the communication protocol between users and eRACE servers. To this end, the front-end interface of eRACE was implemented as a Java applet with an embedded transporter able to launch and receive Concordia Agents. ‘Agent-proxies’ were implemented as stationary Concordia Agents able to launch mobile agents to access and combine information sources over the network.

2.2. System architecture

2.2.1. First tier

eRACE is organized as a two-tier architecture (see Fig. 1). The first tier includes modules that manage services provided to users: the Service Manager, Content-Distribution Agents, and Personal Information Roadmap (PIR) Servlets.

The *Service Manager* is comprised of modules for handling user connection (authentication, login) and profile management. Each time a user connects to eRACE, the Service Manager notifies other modules so that content starts ‘flowing’ to the user. Furthermore, the Service Manager maintains and manages user and service profiles that are defined and stored as XML data. A profile is a set of long-term, continuously evaluated queries [49]; in eRACE, these queries can be typical queries to Web databases, HTTP requests for World-Wide Web resources, access to

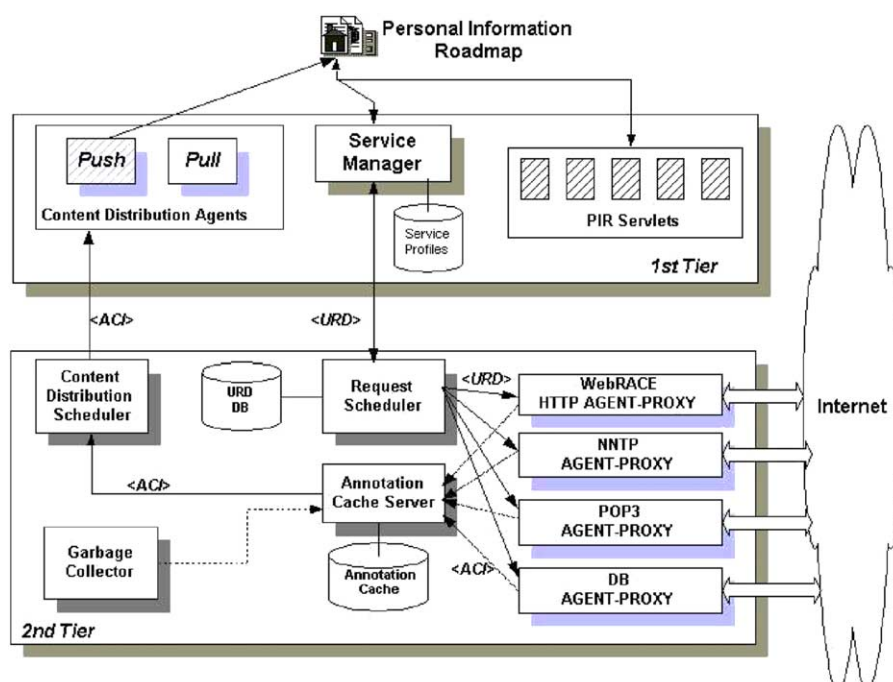

Fig. 1. eRACE system architecture.

general-purpose Search Engines or Subject Cataloging Sites, subscription to Usenet News, etc. Each profile is annotated with a number of *data* and *control* parameters. Data parameters are query arguments, e.g. a stock symbol of interest. Control parameters determine the frequency of query execution, the expected amount of information gathered from queries (e.g. summary vs. full results), the priority of notification for a given query, etc. Profiles are managed by the Service Manager through the Java API of PDOM [33], which is a thread-safe, persistent Document Object Model data manager. The Service Manager translates these profiles into eRACE requests that are forwarded for execution to the second tier of eRACE (see Fig. 1).

Content-Distribution Agents retrieve content pertinent to user and service profiles, and maintained in the caches of eRACE's Agent-Proxies (with meta-information kept in the Annotation Cache). Content is aggregated by the CDA's, which decide when and how to disseminate it to end-users, following possible terminal- or connection-specific transformations (adaptation, transcoding, etc.). Additional optimizations, such as caching content within the Content-Distribution Agents 'near' the PIR Servlets, will be addressed in future work.

eRACE provides users with seamless access to their content through the PIR. This is a customized user-interface that implements a simple e-mail based information provision paradigm, seeking to cope with problems of network disorientation and information overloading. The PIR provides a user with a personalized and unified view of her personal information space across different devices. The PIR is implemented as a set of Java Servlets, which transcode it to a format appropriate for the users' terminal connections (HTML for connections over HTTP and WML for connections over WAP). The PIR can be used simultaneously with other tools employed to access information on Internet (browsers, e-mailers, etc.).

2.2.2. Second tier

The second tier of eRACE consists of a number of protocol-specific *agent-proxies* like WebRACE, mailRACE, newsRACE and dbRACE that retrieve and cache information from the WWW, POP3 e-mail accounts, USENET NNTP-news, and Web-database queries, respectively (see Fig. 1).

Agent-proxies are driven by a *Request Scheduler*, which scans continuously a database of *Unified Resource Descriptions* (URD-DB in Fig. 1) and schedules URD's for execution to the corresponding agent-proxy. A *Unified Resource Description* (URD) is an XML-encoded data-structure, which is part of an 'eRACE request,' and describes source information, processing directives and urgency information for Internet sources monitored by eRACE. In essence, each URD represents a request to retrieve and process content from a particular Internet source on behalf of a particular user or service. A typical URD request is shown in Table 1.

Table 1

A typical URD instance

```

< urd >
  < uri timing = "600000" lastcheck = "97876750000" port = "80" >
    http://www.cs.ucy.ac.cy/default.html
  </uri >
  < type protocol = "http" method = "pull" processtype = "filter"/>
  < keywords >
    < keyword key = "ibm" weight = "1"/>
    < keyword key = "research" weight = "3"/>
    < keyword key = "java" weight = "4"/>
    < keyword key = "xmlp4j" weight = "5"/>
  </keywords >
  < depth level = "4"/>
  < urgency urgent = "1"/>
</urd >

```

The URD database (URD-DB) is populated by the Service Manager of eRACE. URD-DB is a single XML-encoded document managed by PDOM [33]. XML documents are parsed by PDOM and stored in Java serialized binary form on secondary storage, organized in pages, each containing 128 DOM nodes of variable length. The parsed document is accessible to DOM operations directly, without re-parsing. PDOM nodes accessed by a DOM operation are loaded into a main memory cache. PDOM supports main-memory caching of XML nodes, enabling fast searches in the DOM tree.

Access to URD-DB's contents is provided through the data manager of PDOM, which issues XQL queries (eXtensible Query Language) to a GMD-IPSI XQL engine [33,41]. This engine is a Java-based storage and query application, which handles large XML documents and incorporates two key mechanisms: a persistent implementation of W3C-DOM Document objects [2], and a full implementation of the XQL query language.

The content produced by a URD execution is stored in the software cache of the corresponding agent-proxy and filtered by the AE of eRACE according to processing directives defined in that URD. Meta-information produced by the filtering process is encoded as an XML data-structure named *Annotation Cache Information* (ACI) and cached separately. ACIs are used by *Content-Distribution Agents* for information dissemination to end-users. ACI is an extensible data-structure that encapsulates information about the Web source that corresponds to the ACI, the potential user-recipient(s) of the 'alert' that will be generated by eRACE's Content-Distribution Agents according to the ACI, a pointer to the cached content, a description of the content (format, file size, extension), a classification of this content according to its urgency and/or expiration time, and a classification of the document's relevance with respect to the semantic interests of its potential recipient(s). The XML description of the ACIs is extensible and therefore we can easily include additional information in it without having to change the architecture of WebRACE. ACIs are stored in an XML-ACI PDOM database. An example of a typical ACI snippet is given in Table 2.

Table 2
ACI snippet

```

< aci owner = "csyiaztl" extension = "html"
format = "html"
  relevance = "18" updatetime = "97876950000"
filesize = "2000" >
  < uri > http://www.cs.ucy.ac.cy/default.html
</uri >
  < urgency urgent = "1"/>
  < docbase > 969890.gzip </docbase >
  < expired expir = "false"/>
  < summary > This is a part of the document with
keywords 1) ... </summary >
</aci >
    
```

Agent-proxies implement a number of optimizations such as coalescing different URD requests that target the same information source. Furthermore, agent-proxies implement expiration policies that differ from the expiration policies of information sources on Internet. eRACE maintains and manages multiple versions of the content published on some information source every time this content is of interest to some eRACE profile, and for as long as the resulting information has not been retrieved by interested end-users. This approach makes it necessary to manage obsolete information stored in eRACE caches explicitly. This task is carried out by a Garbage Collector module (see Fig. 1).

3. WebRACE design and implementation challenges

WebRACE is the agent-proxy that deals with information sources on the WWW and accessible through

the HTTP protocols (HTTP/1.0, HTTP/1.1). Other proxies have the same general architecture with WebRACE, differing only in the implementation of their protocol-specific proxy engines.

WebRACE is comprised of three basic components: the *Mini-Crawler*, the *Object Cache*, and the AE. These components operate independently and asynchronously (see Fig. 2). They can be distributed to different computing nodes, execute in different Java heap-space s, and communicate through permanent socket links. Through these sockets, the Mini-Crawler notifies the AE every time it fetches and caches a new page in the Object Cache. The AE can then process the fetched page asynchronously, according to pre-registered user profiles or other criteria.

In the development of WebRACE, we address a number of challenges: first, is the design and implementation of a user-driven crawler. Typical crawlers employed by major search engines such as Google [13], start their crawls from a carefully chosen fixed set of ‘seed’ URL’s. In contrast, the Mini-Crawler of WebRACE receives continuously crawling directives which emanate from a queue of standing eRACE requests (see Fig. 2). These requests change dynamically with shifting eRACE-user interests, updates in the base of registered users, changes in the set of monitored resources, etc.

A second challenge is to design a crawler that monitors Web-sites exhibiting frequent updates of their content. WebRACE should follow and capture these updates so that interested users are notified by eRACE accordingly. Consequently, WebRACE is expected to crawl and index parts of the Web under short-term time constraints and keep

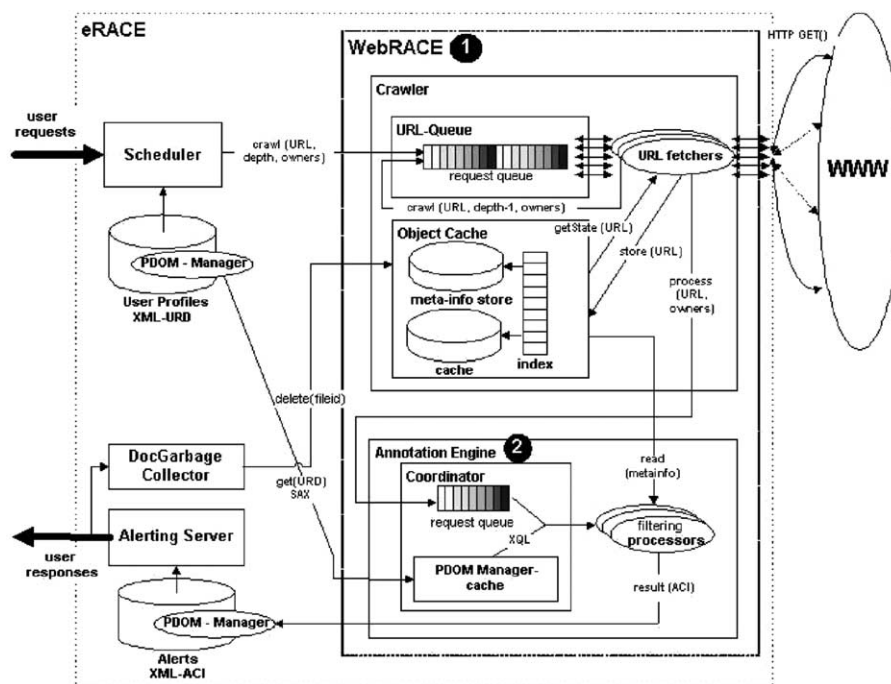

Fig. 2. WebRACE system architecture.

multiple versions of the same Web-page in its store, until all interested users receive the corresponding alerts.

Similarly to personal and site-specific crawlers like SPHINX [38], WebRACE is customized and targets specific Web-sites. These features, however, must be sustained in the presence of a large and increasing user base, with varying interests and different service-level requirements. In this context, WebRACE must be scalable, sustaining high-performance and short turn-around times when serving many users and crawling a large portion of the Web. To this end, it should avoid duplication of effort and combine similar requests when serving similar user profiles. Furthermore, it should provide built-in support for QoS policies involving multiple service-levels and service-level guarantees. Consequently, the scheduling and performance requirements of WebRACE crawling and filtering face very different constraints than systems like Google [13], Mercator [32], and SPHINX [38].

Finally, WebRACE is implemented entirely in Javav.1.3. Extensive performance and memory debugging with the OptimizeIt profiler [48], however, identified a number of performance problems arising because of Java core classes (excessive allocation of new objects causing heap-space overflows and performance degradation). Consequently, we developed our own data-structures that use a bounded amount of heap-space regardless of the crawl size, and maintain part of their data on disk. Furthermore, we rewrote some of the mission-critical Java classes, streamlining very frequent operations. More information on implementation details can be found in Refs. [52,53].

4. The Mini-Crawler of WebRACE

A crawler is a program that traverses the hypertext structure of the Web automatically, starting from an initial hyper-document and recursively retrieving all documents accessible from that document. Web crawlers are also referred to as robots, wanderers, or spiders. Typically, a crawler executes a basic algorithm that takes a list of seed URL's as its input, and repeatedly executes the following steps [32]. It initializes the crawling engine with the list of seed URL's and pops a URL out of the URL list. Then, it determines the IP address of the chosen URL's host name, opens a socket connection to the corresponding server, asks for the particular document, parses the HTTP response header and decides if this particular document should be downloaded. If this is so, the crawler downloads the corresponding document and extracts the links contained in it; otherwise, it proceeds to the next URL. The crawler ensures that each extracted link corresponds to a valid and absolute URL, invoking a URL-normalizer to 'de-relativize' it, if necessary. Then, the normalized URL is appended to the list of URL's scheduled for download, provided this URL has not been fetched earlier.

In contrast to typical crawlers [32,38], WebRACE refreshes continuously its URL-seed list from requests posted by the eRACE *Request Scheduler*. These requests have the following format:

[Link, ParentLink, Depth, {owners}]

Link is the URL address of the Web resource sought, *ParentLink* is the URL of the page that contained *Link*, *Depth* defines how deep the crawler should 'dig' starting from the page defined by *Link*, and {*owners*} contains the list of eRACE users potentially interested in the page that will be downloaded.

The Mini-Crawler is configurable through configuration files and can be adapted to specific crawl tasks and benchmarks. The crawling algorithm described in Section 3 requires a number of components, which are listed and described in detail below:

- The *URLQueue* for storing links that remain to be downloaded.
- The *URLFetcher* that uses HTTP to download documents from the Web. The *URLFetcher* contains also a *URL extractor and normalizer* that extracts links from a document and ensures that the extracted links are valid and absolute URL's.
- The *Object Cache*, which stores and indexes downloaded documents, and ensures that no duplicate documents are maintained in cache. The *Object Cache*, however, can maintain multiple versions of the same URL, if its contents have changed with time.

4.1. The *URLQueue*

The *URLQueue* is an implementation of the *SafeQueue* data-structure that we designed and implemented to achieve the efficient and robust operation of WebRACE and to overcome problems of the `java.util.LinkedList` component of Java [28]. *SafeQueue* is a circular array of *QueueNode* objects with its own memory-management mechanism, enabling the re-use of objects and minimizes garbage-collection overhead. Moreover, *SafeQueue* provides support for persistence, overflow control, disk caching, multithreaded access, and fast indexing to avoid the insertion of duplicate *QueueNode* entries [52,53].

URLQueue is a *SafeQueue* subclass comprised of *URLQueueNode*'s, i.e. Java objects that represent requests coming from the Request Scheduler of eRACE. During the server's initialization. The length of the *URLQueue* is determined during WebRACE initialization from its configuration files. At initialization time, WebRACE allocates the heap-space required to store all the nodes of the queue. This approach is chosen instead of allocating *Queue Nodes* on demand for memory efficiency and performance. In our experiments, we configured the *URLQueue* size to two million nodes, i.e. 2 million URL's. This number corresponds to approximately 27 MB of heap-space. A larger *URLQueue* can be employed,

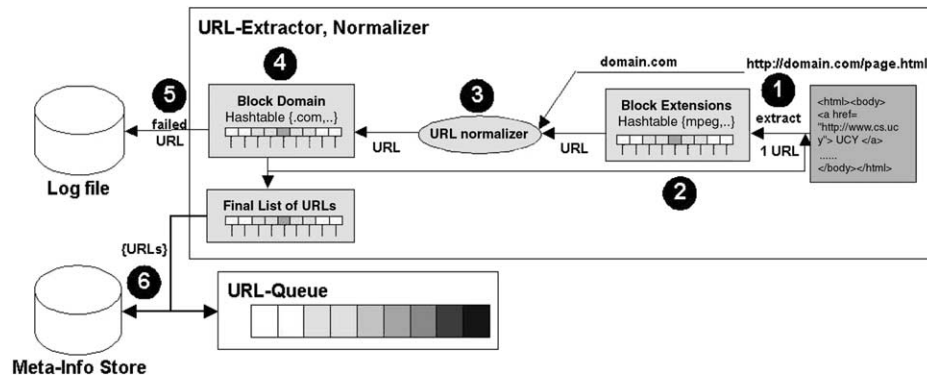

Fig. 3. URL extractor architecture.

however, at the expense of heap size available for other components of WebRACE.

4.2. The URLFetcher

The *URLFetcher* is a multithreaded WebRACE that fetches documents from the Web using the HTTP/1.0 and HTTP/1.1 protocols. *URLFetcher* threads retrieve pending requests from the *URLQueue*, conducting synchronous I/O to download WWW content, and overlapping I/O with computation. In the current version of WebRACE, resource management and thread scheduling is left to Java's runtime system and the underlying operating system. The number of available *URLFetcher* threads, however, can be configured during the initialization of the WebRACE-server.

In addition to handling HTTP connections, the *URL-Fetcher* processes downloaded documents. To this end, it invokes its *URLExtractor and normalizer* sub-component. The *URLExtractor* extracts links (URL's) out of a page, disregards URL's pointing to uninteresting resources, normalizes the URL's so that they are valid and absolute and, finally, adds these links to the *URLQueue*. As shown in Fig. 3, the *URLExtractor and normalizer* works as a 6-step pipe within the *URLFetcher*.

5. The Object Cache

The *Object Cache* is the component responsible for managing documents cached in secondary storage. It is used for storing downloaded documents that will be retrieved later for processing, annotation, and subsequent dissemination to eRACE users. The *Object Cache*, moreover, caches the crawling state in order to coalesce similar crawling requests and to accelerate the re-crawling of WWW resources that have not changed since their last crawl.

The *Object Cache* is comprised of an *Index*, a *Meta-info Store* and an *Object Store* (see Fig. 2). The *Index* resides in main memory and indexes documents stored on disk; it is implemented as a `java.util.HashMap`, which contains URL's that have been fetched and stored in WebRACE. That way, *URLFetcher*'s can check if a page

has been re-fetched, before deciding whether to download its contents from the Web. The *Meta-info Store* collects and maintains meta-information for cached documents. Finally, the *Object Store* is a directory in secondary storage that contains a compressed version of downloaded resources.

The *Meta-info Store* maintains a meta-information file for each Web document stored in the *Object Cache*. Furthermore, a key for each meta-info file is kept with the *Index* of the *Object Cache* to allow for fast look-ups. The contents of a meta-info file are encoded in XML and include: (i) the URL address of the corresponding document; (ii) the IP address of its origin Web server; (iii) the document size in KiloBytes; (iv) the Last-Modified field returned by the HTTP protocol during download; and (v) the HTTP response header, and all extracted and normalized links contained in this document. An example of a meta-info file is given in Table 3.

Normally, a *URLFetcher* executes the following algorithm to download a Web page:

1. Retrieve a *QueueNode* from the *URLQueue* and extract its URL.

Table 3
Example of meta-information file

```
< webrace:url > http://www.cs.ucy.ac.cy/~ep1121/
< /webrace:url >
< webrace:ip > 194.42.7.2 < /webrace:ip >
< webrace:kbytes > 1 < /webrace:kbytes >
< webrace:ifmodifiedsince >
989814504121 < /webrace:ifmodifiedsince >
< webrace:header >
HTTP/1.0 200 OK
Server: Netscape-FastTrack/2.01
Date: Fri, 11 May 2001 13:50:10 GMT
Accept-ranges: bytes
Last-modified: Fri, 26 Jan 2001 21:46:08 GMT
Content-length: 1800
Content-type: text/html
< /webrace:header >
< webrace:links >
http://www.cs.ucy.ac.cy/Computing/labs.html
http://www.cs.ucy.ac.cy/
http://www.cs.ucy.ac.cy/helpdesk
< /webrace:links >
```

2. Retrieve the URL and analyze the HTTP-header of the response message. If the host server contains the message ‘200 Ok,’ proceed to the next step. Otherwise, continue with the next QueueNode.
3. Download the body of the document and store it in main memory.
4. Extract and normalize all links contained in the downloaded document.
5. Compress and save the document in the Object Cache.
6. Save a generated meta-info file in the Meta-info Store.
7. Add the key (hashCode) of the fetched URL to the Index of the Object Cache.
8. Notify the AE that a new document has been fetched and stored in the Object Cache.
9. Add all extracted URL’s to the URLQueue.

To avoid the overhead of the repeated downloading and analysis of documents that have not changed, we alter the above algorithm and use the Meta-info Store to decide whether to download a document that is already cached in WebRACE. More specifically, we change the second and third steps of the above crawling algorithm as follows:

2. Access the Index of the Object Cache and check if the URL retrieved from the URLQueue corresponds to a document fetched earlier and cached in WebRACE.

3. If the document is not in the Cache, download it and proceed to step 4. Otherwise:

- Load its meta-info file and extract the HTTP Last-Modified time-stamp assigned by the origin server. Open a socket connection to the origin server and request the document using a conditional *HTTP GET* command (*if-modified-then*), with the extracted time-stamp as its parameter.
- If the origin server returns a ‘304 (not modified)’ response and no message-body, terminate the fetching of

this particular resource, extract the document links from its meta-info file, and proceed to step 8.

- Otherwise, download the body of the document, store it in main memory and proceed to step 4.

If a cached document has not been changed during a re-crawl, the URLFetcher proceeds with crawling the document’s outgoing links, which are stored in the Meta-info Store and which may have changed.

6. The Annotation Engine (AE)

The Annotation Engine (AE) processes documents that have been downloaded and cached in the *Object Cache* of WebRACE. Its purpose is to ‘classify’ collected content according to user-interests described in eRACE profiles. The meta-information produced by the processing of the AE is stored as eRACE annotations (ACIs) linked to the cached content. Pages that are not relevant to any user-profile are dropped from the cache.

Personalized AEs are not used in typical Search Engines [13], which employ general-purpose indices instead. To avoid the overhead of incorporating a generic look-up index in WebRACE that will be updated dynamically as resources are downloaded from the Web, we designed the AE so that it processes downloaded pages ‘on the fly.’ Therefore, each time the AE receives a ‘process(file,users)’ request through established socket connections with the Mini-Crawler, it inserts the request in the *Coordinator*, which is a SafeQueue data-structure (see Fig. 4). Multiple *Filtering Processors* (FPs) remove requests from the Coordinator and process them according to the URD’s of eRACE users contained in the request. Currently, the AE implements a well-known

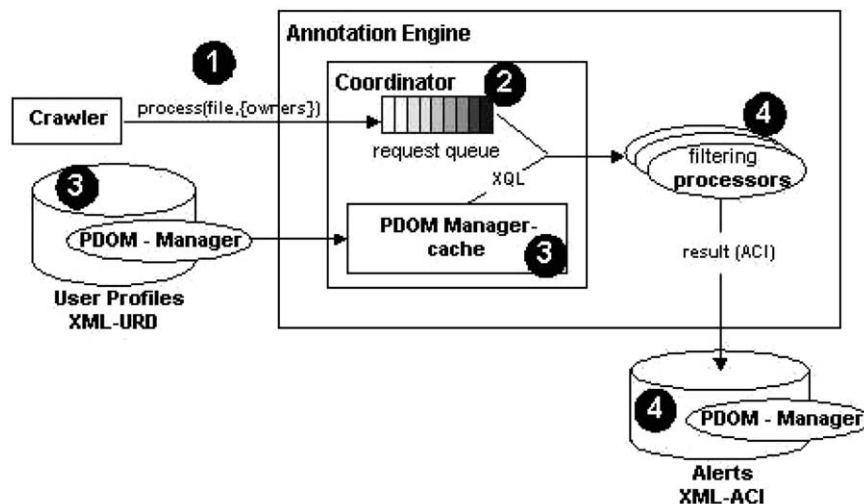

Fig. 4. WebRACE annotation engine.

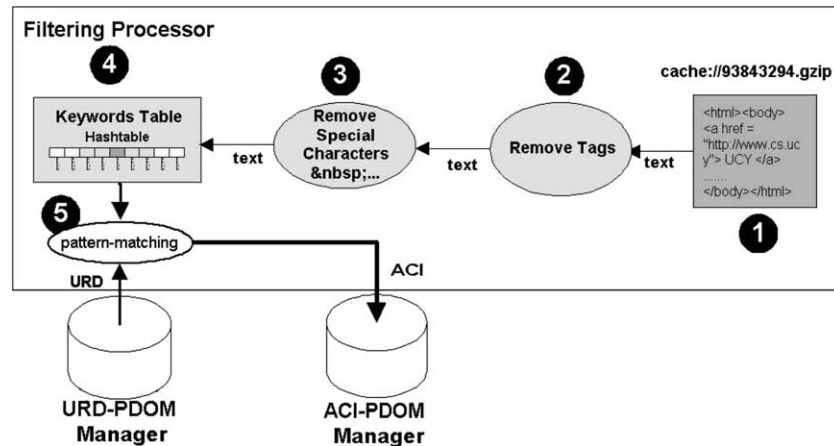

Fig. 5. The filtering processor.

string-matching algorithm looking for weighted keywords that are included in the user-profiles [49].

FP is the component responsible for evaluating if a document matches the interests of a particular eRACE-user, and for generating an ACI out of a crawled page (see Fig. 5). The FP works as a pipe of filters. At step 1, FP loads and decompresses the appropriate file from the Object Cache of WebRACE. At step 2, it removes all links contained in the document and proceeds to step 3, where all special HTML characters are also removed. At step 4, any remaining text is added to a Keyword HashTable. Finally, at step 5, a pattern-matching mechanism loads sequentially all the required URD elements from the URD-PDOM and generates ACI meta-information, which is stored in the ACI-PDOM (step 6). This pipe requires an average of 200 ms to calculate the ACI for a 70 kB Web page, with three potential recipients.

In our experiments, we have configured the SafeQueue size of the AE to 1000 nodes, which proved to be adequately large in experiments conducted with 10 Filtering-processor threads and 100 URLFetcher threads.

7. Experiments and performance assessment

To evaluate the performance of WebRACE we ran a number of tests and extracted measurements of performance-critical components. In particular, we investigated the benefits of caching the crawling state, the overall performance of the crawler, and the effects that multithreading has on URLFetcher performance. For our experiments, we crawled three classes of Web-sites: the first class includes servers that provide content which does not change very frequently (remote University sites in the US); the second class consists of popular news-sites, search-engine sites and portals (cnn.com, yahoo.com, msn.com, etc.); the third class consists of Web servers residing in our departmental network.

7.1. Overall performance and benefits from caching crawling state

To assess the performance improvement achieved caching crawling state in the Meta-info Store, we conducted experiments with the first two classes of Web-sites. For these experiments we configured WebRACE to use 150 concurrent URLFetchers and ran it on our dual-processor Sun Enterprise E250 Server, with the Annotation Processor running concurrently with 10 threads on a Sparc 5.

The diagram of Fig. 6 (left) presents the progress of the crawl and re-crawl operations for the first class of sites. The time interval between the crawl and the subsequent re-crawl was 1 h; within that hour the crawled documents had not changed at all. The delay observed for the re-crawl operation is attributed to the HTTP ‘if-modified-since’ validation messages and the overhead of the Object Cache. As we can see from this diagram, the employment of the Meta-info Store results to an almost three-fold improvement in the crawling performance. Moreover, it reduces substantially the network traffic and the Web-servers’ load generated because of the crawl.

The diagram of Fig. 6 (right) presents our measurements from the crawl and re-crawl operations for the second class of sites. Here, almost 10% of the 993 downloaded documents change between subsequent re-crawls. From this diagram we can easily see the performance advantage gained by using the Meta-info Store to cache crawling meta-information: from a throughput of 3.37 requests/s of the first crawl, we achieve throughput of 8.31 and 20.77 requests/s for the two subsequent re-crawls, respectively.

It should be noted that within the first 100 ms of all these crawling experiments, crawling and re-crawling exhibit practically the same performance behavior. This is attributed to the fact that most of the crawled portals reply to our HTTP GET requests with ‘301 (Moved Permanently)’ responses, and re-direct our crawler to other URL’s. In these cases, the crawler terminates the connection and schedules

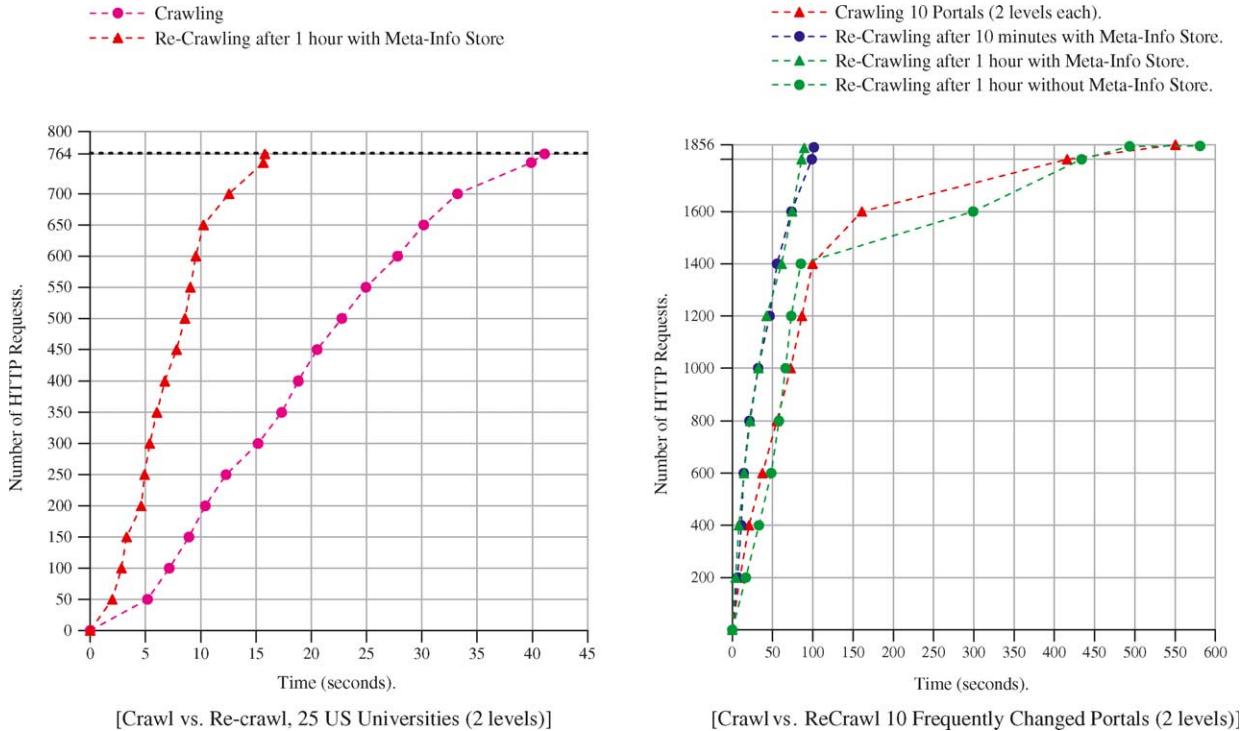

Fig. 6. Crawling vs. re-crawling in WebRACE.

immediately a new HTTP GET operation to fetch the requested documents from the re-directed address.

Finally, in Fig. 7, we present measurements from a longer crawl that took 29.38 min to complete and produced 11,669 documents. This crawl was conducted on our (slow) departmental Web servers.

7.2. URLFetcher performance

To evaluate the overall performance of the URLFetcher, we ran a number of experiments launching many concurrent fetchers that try to establish TCP connections and fetch documents from Web servers located on our 100 Mbits LAN. Each URLFetcher pre-allocates all of its required resources before the benchmark start-up. The benchmarks ran on a 360 MHz UltraSPARC-IIi, with 128 MB RAM and Solaris 5.7.

As we can see from Fig. 8, the throughput increases with the number of concurrent URLFetchers, until a peak P is reached. After that point, throughput drops substantially, because of the synchronization overhead incurred by the large number of concurrent threads. This crawling process took a very short time (3 min with only one thread), which is actually the reason why the peak value P is 40. In this case, URLQueue empties very fast, limiting the utilization of URLFetcher's near the benchmark's end. Running the same benchmark for a lengthy crawl we observed that 100 concurrent URLFetcher's achieve optimal crawling throughput.

7.3. Distributed Mini-Crawler execution

In order to speed-up the performance of WebRACE, we sought to parallelize the Mini-Crawler by running multiple multithreaded URLFetcher's on a network of workstations, keeping the number of threads at each workstation optimal. To this end, we employed the Java-based *Distributed Data-Structure* component, which was developed at UC/Berkeley

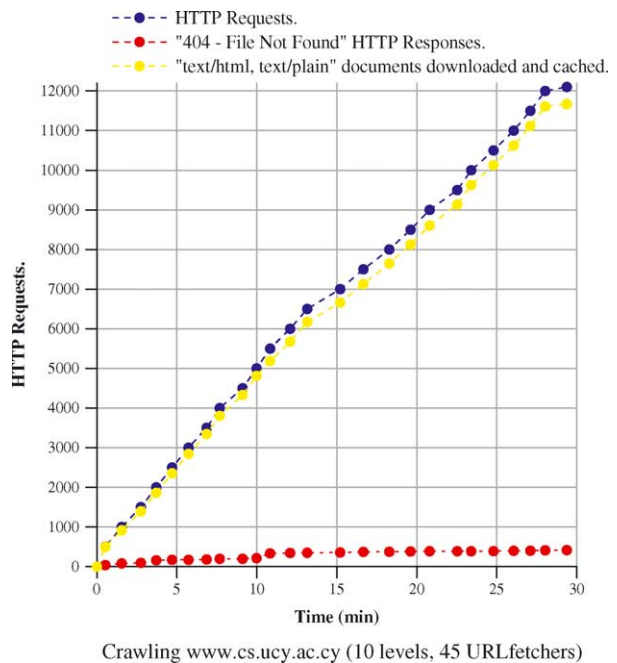

Fig. 7. Performance of a longer crawl.

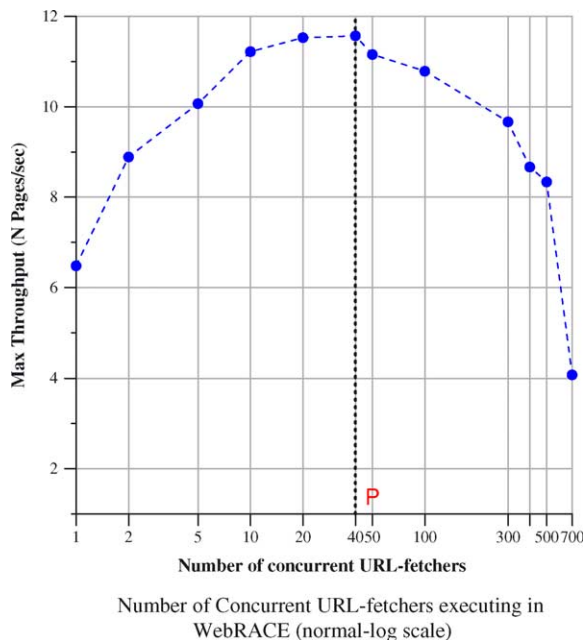

Fig. 8. URLFetcher throughput degradation.

[29]. The DDS component distributes and replicates the contents of a data-structure across a cluster or network of workstations, providing the programmer with a conventional, single-site, in-memory interface to the data-structure [29]. Coherence between distributed replicas is established through an implementation of a two-phase commit protocol, which is transparent to the programmer of services on top of DDS.

When using the DDS layer and API, we kept the core of WebRACE intact and added-on a module that could handle

the distribution of the Mini-Crawler. To this end, we ran multiple URLFetchers on different machines and used the Distributed Hashtable implementation of DDS [29] to index the documents gathered by the URLFetchers, allowing the crawlers to know the content of the Meta-info Store. The total time spent to incorporate the DDS in WebRACE and make it distributed was less than 3 h.

The topology of the distributed Mini-Crawler is presented in Fig. 9. We employed eight crawling nodes, one DDS indexing node, and one control terminal for monitoring and control. The crawling nodes are IBM 43P workstations running AIX, SPARC workstations running Solaris, and a dual processor Sun Enterprise E250 server, all connected on our 10/100 Mbps Local Area Network.

To assess the performance improvement provided by the distribution of WebRACE, we conducted an experiment crawling our first class of servers (University sites) in a depth of three levels. To this end, we configured each crawling node to use only 45 concurrent URLFetchers. Measurements are presented in Fig. 10, which shows that the performance of the distributed WebRACE scales linearly with the number of crawling nodes. It is interesting to note that for 45 concurrent URLFetcher threads, the performance of the distributed WebRACE with one crawling node is better than that of the ‘standalone’ WebRACE. This is attributed to the poor performance of the synchronized `java.util.HashMap` used in the latter case. Finally, different crawling nodes display a different crawling throughput: on the average, the E250 dual processor server was three times faster than the SPARC-stations, and almost 10 times faster than the AIX machines.

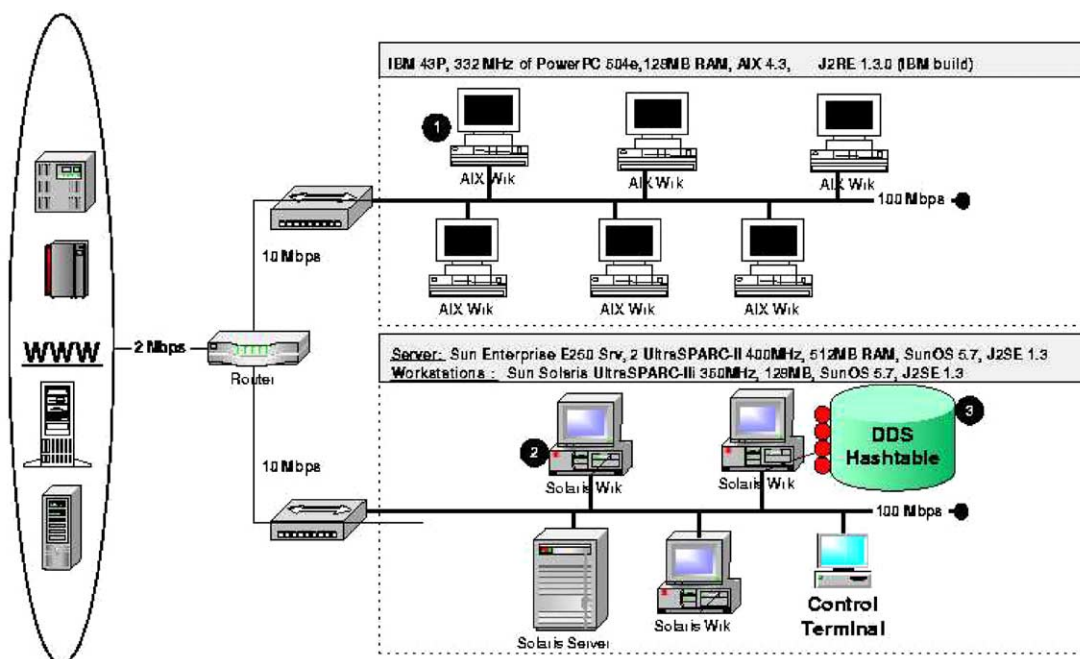

Fig. 9. WebRACE distributed crawler network topology.

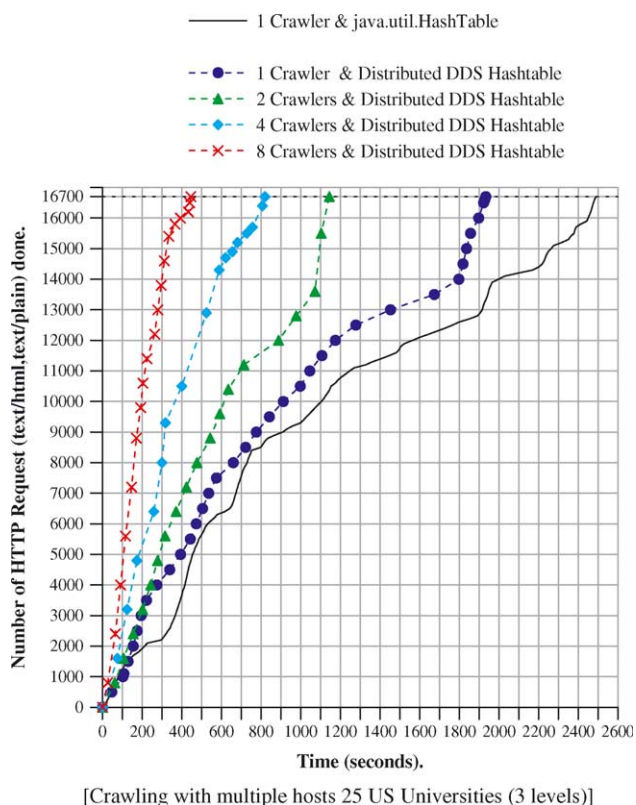

Fig. 10. WebRACE distributed crawler performance.

8. Related work

8.1. Intermediaries

Research and development on intermediary software for Internet has produced a variety of systems, ranging from proxy servers [19], subscription-based notification and information dissemination services [6,21,25,43,49], tools that support mobile Web access [27], and more generic, programmable infrastructures that can be used to build ubiquitous services [7,11,26,30]. These systems can be analyzed in the context of the architectural and functional specifications for ‘Open Pluggable Edge Services’ (OPESs), which are proposed by the IETF’s OPES working group for describing intermediary services in open, distributed settings [1,3]. Intermediary software can be characterized as ‘middleware,’ since it provides a ‘reusable and expandable set of services and functions, commonly needed by many applications to function well in a networked environment’ [5]. Here, we describe some characteristic examples of intermediary infrastructures. A more detailed survey can be found in Ref. [20].

A programmable framework for building various intermediary services is the *Web Browser Intelligence* or *Web Intermediaries* (WBI) by IBM Almaden [7,8,37]. WBI is a programmable proxy server designed for

the development and deployment of intermediary applications. The design of WBI is based on the notion of ‘information streams’ that convey data from information providers (e.g. a Web server) to information consumers (e.g. a Web browser), and can be classified into unidirectional and bidirectional messages or transaction streams [9]. WBI has been used to develop a number of applications such as a manager-repository for *cookies* and a Web-browsing service for mobile devices [7]. WBI plugins can be installed both on a client machine and on any other networked machine, possibly near an origin server. Multiple client-side and server-side WBI intermediaries can cooperate to establish one WBI service.

Building mobile services from proxy components is the main goal of the *iMobile* project of AT&T Research [16,45]. The *iMobile* proxy maintains user and device profiles, accesses and processes Internet resources on behalf of the user, keeps track of user interaction and performs content transformations according to device and user profiles. The architecture of *iMobile* is established upon the infrastructure of *iProxy*, a programmable proxy server designed to host agents and personalized services developed in Java [46]. *iMobile* consists of three main abstractions: *devlets*, *infolets* and *applets*. A *devlet* is an agent-abstraction for supporting the provision of *iMobile* services to different types of mobile devices connected through various access networks. A *devlet*-instance communicates with a device-specific ‘driver’ that is either co-located in the *iProxy* server or resides at a remote mobile support station. The *infolet* abstraction provides a common way of expressing the interaction between the *iMobile* server and various information sources or information spaces (in *iMobile* terminology) at a level higher than the HTTP protocol and the URI specification. Different sources export different interfaces to the outside world: JDBC and ODBC for corporate databases, the X10 protocol for home networks, IMAP for e-mail servers, etc. Finally, an *iMobile* applet is a module that processes and aggregates content retrieved by different sources and relays results to various destination devices. At the core of an *iMobile* server resides the ‘let engine,’ which registers all *devlets*, *infolets* and *applets*, receives commands from *devlets*, forwards them to the right *infolet* or *applet*, transcodes the result to an appropriate terminal-device format and forwards it to the terminal device via the proper *devlet*.

A broader approach that seeks to develop a robust infrastructure and programming platform for Internet-scale systems and services in Java comes from the *Ninja* project at UC/Berkeley [30]. The architecture of *Ninja* consists of *bases*, *active proxies*, *units* and *paths*. *Bases* are scalable platforms designed to host Internet services. They consist of a programming model and I/O substrate designed to provide high-concurrency, robustness, and transparent distribution of data to cluster-nodes [29]. Moreover, they include a cluster-based execution environment (*vSpace*) that provides facilities for service component replication,

load-balancing and fault-tolerance [30]. The programming model of Ninja consists of four *design patterns* that service programmers can use to compose different stages of a single service: wrap, pipeline, combine and replicate [30]. Active proxies are fine-grain intermediaries providing transformational support between Ninja services and terminal devices. Active proxies perform data distillation, protocol adaptation, caching, encryption, etc. Examples of active proxies include wireless base-stations, network gateways, firewalls, and caching proxies. In Ninja terminology, a path is a flow of typed data through multiple proxies across a wide-area network; each proxy performs transformational operations to adapt the data into a form acceptable by the next service or device along the path. Similarly to WBI plugins, Ninja-paths can be established dynamically. Finally, units are abstractions for the client devices attached to the Ninja infrastructure, which range from PC's and laptops to mobile devices, sensors and actuators.

8.2. Crawlers

Crawlers have been a topic of intensive research in a number of contexts [13,14,17,18,38,40,44]. Here, we provide a brief overview of crawlers that bare some resemblance with WebRACE in terms of their design or scope. In particular, we focus on the following four classes of crawlers: (i) *parallel*; (ii) *personal*; (iii) *focused*; and (iv) *peer-to-peer*.

(i) *Parallel crawler* employ multiple, concurrent crawling processes to minimize the time of large crawls. Typically, large crawlers are used by popular search engines, Web caches, and other large information retrieval systems. Despite the wide deployment of parallel crawlers, very few published studies have investigated crawling strategies [23] or evaluated crawler performance [17,40]. Cho and Garcia-Molina [17] explore the trade-offs of crawler parallelization and identify a number of parameters that are important in the design of a parallel crawler. According to this work, the main challenge confronting parallel crawlers is how to communicate internal state (i.e. indices, list of pending and downloaded URLs) among the several crawling processes. This challenge arises only for parallel crawlers that work on overlapping sets of URLs; other parallel crawlers restrict the visits of the different processes to separate, pre-determined sets of URLs.¹ Ideally, a crawling system tries to minimize the *overlap* among the concurrent processes, which is achieved by communicating internal state, while at the same time minimize the communication among the various processes distributed across several hosts.

¹ This kind of crawler would be called, according to the terminology of Ref. [17], a *static-assignment firewall-mode crawler*.

- (ii) *Personal crawlers*, such as WebSPHINX [38] and the *Competitive Intelligence (CI) Spider* [15], allow users to 'dispatch' simple crawlers on the Web without the need of acquiring access to dedicated crawling infrastructures. WebSPHINX includes a crawl visualization module, which allows its user to visually inspect accessed pages and broken links. Similar to WebRACE, WebSPHINX supports exhaustive traversal techniques (breadth-first or depth-first traversal), multithreading, and JAVA. Nevertheless, it is designed for single-user usage and therefore does not support runtime scheduling of several crawling requests. The CI Spider collects user specified web pages and performs linguistic analysis and clustering of results. Such results are expected to help users or corporate managers to obtain critical information about some competitive environment (e.g. other companies) and to make informed decisions about important issues (such as investment, marketing or planning). CI Spider is designed to run on a client machine and therefore it is questionable whether it provides the necessary performance scalability in order to extend its coverage to very large sub-domains of the Web.
- (iii) *Focused crawlers*. The inability of traditional personal and parallel crawlers to contextually prioritize the crawling sequence of URLs led to the development of *focused crawlers* [14], that is crawlers seeking and acquiring pages on a specific set of *topics*. Topics are usually provided offline as collections of contextually related documents, such as the documents organized in Web taxonomies (Yahoo! or Dmoz Open Directory). These collections are subsequently utilized for training some given classifier (e.g. a 'Naive' Bayes Classifier [31]). The classifier will then be able to make decisions on whether the crawler should expand on a given URL or whether some URL should be discarded. The selection of the right training set and classifier are critical in the success of a focused crawler, as short-term crawling path decisions may supersede crawling paths that will ultimately lead to a larger set of valuable pages. Subsequent research in Ref. [24] suggests that by using an additional back-crawl phase (i.e. crawling towards the parents rather than children) before proceeding to the crawling phase can further improve the precision of focused crawlers by 50–60%. Although focused crawlers are able to build specialized Web indices with significant savings in hardware and network resources, they are not significantly useful as general purpose crawlers since the latter are interested in eventually exploring a large segment of the WWW graph.
- (iv) *Peer-to-peer crawlers*. Search engines usually rely on expensive centralized infrastructures comprised of clusters of workstations with terabytes of disk storage and many gigabytes of main memory. Although such infrastructures are feasible, they are not very scalable

as many hundreds of gigabytes of new data are added to the WWW on a daily basis. A peer-to-peer approach for addressing the scalability problem is adopted by the Grub Crawler [4], which deploys a peer-to-peer infrastructure at which peers donate their computer's unused bandwidth to help probing the Web for pages that have changed. This reduces the burden of the actual crawler since it does not need to continuously examine which pages have changed and, therefore, can cope with information that changes frequently. A similar approach is followed by the YouSearch project [10] at IBM Almaden, which proposes the deployment of transient peer crawlers to build a search engine that provides 'always-fresh' content. The main idea in YouSearch is that each user using the service contributes its host to become a transient crawler. In effect, this results to a network of transient crawlers in which each crawler maintains an always-fresh snapshot of a pre-specified list of Web resources. Each crawler also sends a compact index of its crawl (i.e. a bloom filter), to a centralized component at regular intervals. This helps the system redirect some user's query to the most relevant crawler, i.e. to the crawler that has content relevant to the query, rather than flooding the network with queries.

8.3. Performance assessment

To assess the performance of WebRACE, we compare it with the crawler of WebSPHINX, since both systems are written in JAVA and support multithreading. We could not compare WebRACE with many commercial (e.g. Overture,

Google or MSN) or research crawlers [13,17,40], as none of them was publicly available. Furthermore, we did not compare WebRACE to existing single-threaded crawlers, such as the unix-based *wget crawler*, since such a comparison would not be fair.

To compare WebRACE and WebSPHINX quantitatively, we deployed both crawlers with a static seed list, that is without injecting new crawl requests at runtime. We made this choice because WebSPHINX does not provide any explicit mechanism to cope with runtime request scheduling. Our benchmark ran on a 2.0 GHz Intel Pentium IV, using 512 MB RAM, running Windows XP and Sun's Java 1.4.2 runtime. Our seed list included the homepages of the 10 University of California campuses, and our crawl spanned three levels for each entry in the seed list. We configured both crawlers to use breadth-first traversal using 40 threads and restricted them to download only content that did not exceed 1 MB. We also configured WebRACE's maximum heap-space (i.e. the maximum space allocated by the runtime) to 150 MB. On the other hand, we allowed WebSPHINX to use a heap of up to 450 MB, since it consumes extraordinary amounts of memory.

As we can see in Fig. 11, the WebRACE crawler outperformed the WebSPHINX crawler as it accomplished the crawl of 4247 objects at an average download rate of 9.3 pages/s. The WebSPHINX crawler on the other hand did not manage to accomplish the crawling task as it crashed with an `Out-of-Memory` exception. We believe that this is caused by the fact the WebSPHINX crawler maintains several in-memory structures. Another observation is that the throughput of the WebSPHINX crawler is consistently

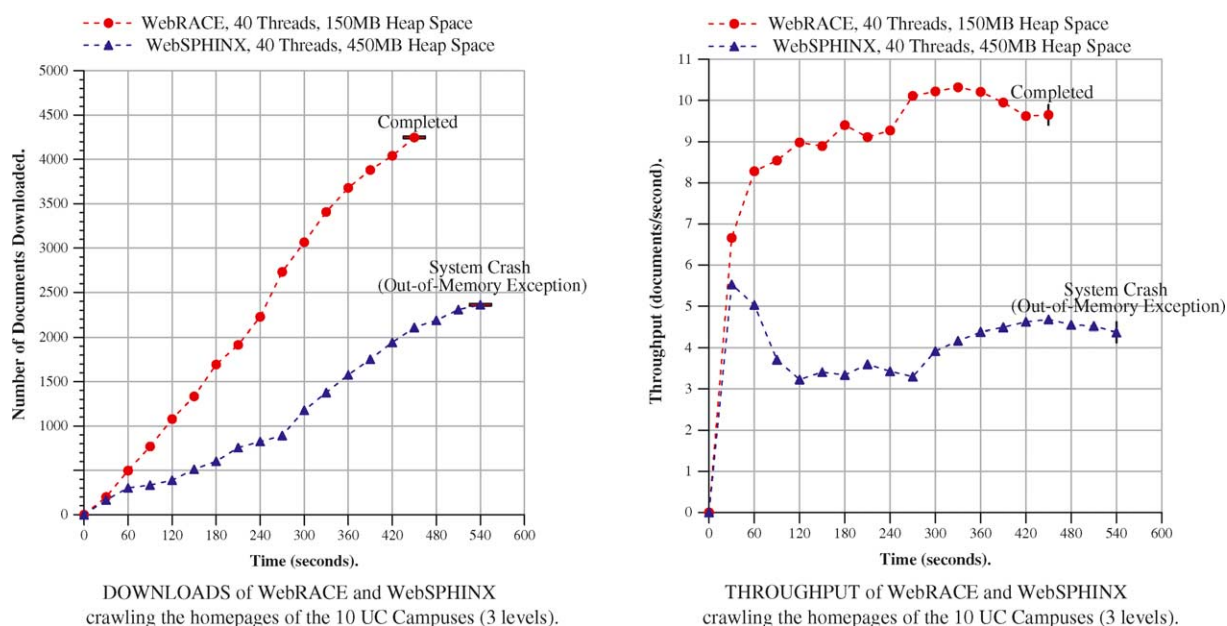

Fig. 11. Crawling the 10 UC campuses using WebRACE and WebSPHINX.

low (≈ 3.9 pages/s). This happens even at the first 120 s, where the crawler does not utilize its whole available heap-space, which implies that the crawler would not be able to perform any better even in the presence of more main memory.

8.4. Remarks

In our work, we address the challenge of designing and implementing modular, open, distributed, and scalable intermediary infrastructures, using Java. Our effort differs from other systems in a number of key issues. (i) Our design is established upon a set of XML grammars that define the information and meta-information collected, generated and exchanged between the various modules of our system. The employment of XML makes it easier to decouple information retrieval, storage and processing from content publishing and distribution. Furthermore, it enables us to describe easily new services, terminal devices, and information sources, without altering the basic design of our infrastructure. Finally, it exports the operations ‘executed’ by the engine to the system-programming level, thus making possible the implementation of different scheduling and resource-management policies according to differentiated service-levels provided to individual users or services. (ii) eRACE consists of modules that communicate via messages and events; therefore, it is relatively easy to distribute these modules to different machines, achieve distributed operation and scalable performance. (iii) Instead of making eRACE a totally generic infrastructure, we developed and optimized modules which provide a functionality necessary nowadays in most intermediary systems: a ‘user-driven’ high-performance crawler, an Object Cache, and a FP. These, performance-critical modules are multithreaded and distributed thanks to the employment of Java and of distributed data-structures in Java. (iv) The development of new services on top of eRACE is supported through the definition of new XML profiles inserted at the information architecture of eRACE. Additional programmability is provided by the employment of the mobile-agent programming paradigm, which supports mobility and disconnected operation of end-users as well. (v) Although a large number of papers have been published on Web crawlers [14,15,18,32,38,40,44], and Internet middleware, the issue of incorporating flexible, scalable and user-driven crawlers in middleware infrastructures remains open. This issue is addressed in the context of WebRACE.

9. Conclusions and future work

In this paper, we presented WebRACE, a World-Wide Web ‘agent-proxy’ that collects, filters and caches Web documents. WebRACE is designed in the context of

eRACE, an extensible Retrieval Annotation Caching Engine. WebRACE consists of a high-performance, distributed Web crawler, a FP, and an Object Cache, written entirely in Java. In our work, we addressed the challenges arising from the design and development of WebRACE. We described our design and implementation decisions, and various optimizations. Furthermore, we discussed the advantages and disadvantages of using Java to implement the crawler, and presented an evaluation of its performance.

To assess WebRACE’s performance and robustness we ran numerous experiments and crawls; several of our crawls lasted for days. Our system worked efficiently and with no failures when crawling local Webs in our LAN and University WAN, and the global Internet. Our experiments showed that our implementation is robust and reliable. The combination of techniques such as, multithreading, caching the crawling state, and the employment of distributed data structures in Java, improved the scalability and performance of WebRACE.

Further optimizations will be included in the near future, so as to prevent our crawler from overloading remote Web servers with too many concurrent requests. We also plan to investigate alternative queue designs and different crawling strategies (breadth-first vs. depth-first) that have been reported to provide improved crawling efficiency.

Acknowledgements

This work was supported in part by the Research Promotion Foundation of Cyprus under grant PENEK 23/2000 and by the European Union under the ANWIRE project (contract IST-2001-38835).

References

- [1] Open Pluggable Edge Services, <http://www.ietf-opes.org>.
- [2] Document Object Model (DOM) Level 1 Specification, W3C recommendation 1, October 1998, <http://www.w3.org/TR/REC-DOM-Level-1/>.
- [3] Open Pluggable Services Working Group Charter, October 2003, <http://www.ietf.org/html.charters/opes-charter.html>.
- [4] Grub—‘help crawl it all’, LookSmart, 2004, <http://www.grub.org/>.
- [5] R. Aiken, M. Carey, B. Carpenter, I. Foster, C. Lynch, J. Mambretti, R. Moore, J. Strasner, B. Teitelbaum, Network Policy and Services: A Report of a Workshop on Middleware, RFC 2768, IETF, 2000, <http://www.ietf.org/rfc/rfc2768.txt>.
- [6] D. Aksoy, M. Altinel, R. Bose, U. Cetintemel, M.J. Franklin, J. Wang, S.B. Zdonik, Research in data broadcast and dissemination, in: Proceedings of the First International Conference on Advanced Multimedia Content Processing, AMCP’98, Lecture Notes in Computer Science, Springer, Berlin, 1999, pp. 194–207.
- [7] R. Barrett, P. Maglio, Intermediaries: new places for producing and manipulating web content, Computer Networks and ISDN Systems 30 (1–7) (1998) 509–518.

- [8] R. Barrett, P. Maglio, Intermediaries: new places for producing and manipulating web content, in: *Proceedings of the Seventh International World Wide Web Conference (WWW7)*, 1998.
- [9] R. Barrett, P. Maglio, Intermediaries: an approach to manipulating information streams, *IBM Systems Journal* 38 (4) (1999) 629–641.
- [10] M. Bawa, R.J. Bayardo, S. Rajagopalan, E. Shekita, Make it fresh, make it quick—searching a network of personal web servers, in: *Proceedings of the Twelfth International World-Wide Web Conference*, ACM Press, New York, 2003.
- [11] E. Brewer, R. Katz, E. Amir, H. Balakrishnan, Y. Chawathe, A. Fox, S. Gribble, T. Hodes, G. Nguyen, V. Padmanabhan, M. Stemm, S. Seshan, T. Henderson, A network architecture for heterogeneous mobile computing, *IEEE Personal Communications Magazine* 5 (5) (1998) 8–24.
- [12] E.A. Brewer, Lessons from giant-scale services, *Internet Computing* 5 (4) (2001) 46–55.
- [13] S. Brin, L. Page, The anatomy of a large-scale hypertextual (web) search engine, *Computer Networks and ISDN Systems* 30 (1–7) (1998) 107–117.
- [14] S. Chakrabarti, M. vanden Berg, B. Dom, Focused crawling: a new approach to topic-specific web resource discovery, in: *Eighth World Wide Web Conference*, Toronto, May, 1999.
- [15] M. Chau, H. Chen, Personalized and focused web spiders, in: N. Zhong, J. Liu, Y. Yao (Eds.), *Web Intelligence*, Springer, Berlin, 2003, pp. 197–217, (Chapter 10).
- [16] Y.-F. Chen, H. Huang, R. Jana, T. Jim, M. Hiltunen, S. John, S. Jora, R. Muthumanickam, B. Wei, iMobile EE: an enterprise mobile service platform, *Wireless Networks* 9 (4) (2003) 283–297.
- [17] J. Cho, H. Garcia-Molina, Parallel crawlers, in: *Proceedings of the Eleventh International World-Wide Web Conference*, May, ACM Press, New York, 2002, pp. 124–135.
- [18] J. Cho, H. Garcia-Molina, L. Page, Efficient crawling through URL ordering, in: *Proceedings of the Seventh International WWW Conference*, April, 1998, pp. 161–172.
- [19] I. Cooper, I. Melve, G. Tomlinson, Internet Web Replication and Caching Taxonomy, IETF, RFC 3040, January 2001, <http://www.ietf.org/rfc/rfc3040.txt>.
- [20] M. Dikaiakos, Intermediary infrastructures for the world-wide web, *Computer Networks*, Elsevier 45 (4) (2004) 421–447.
- [21] M. Dikaiakos, D. Gunopulos, FIGI: the architecture of an internet-based financial information gathering infrastructure, in: *Proceedings of the International Workshop on Advanced Issues of E-Commerce and Web-based Information Systems*, IEEE-Computer Society, Silver Spring, MD, 1999, pp. 91–94.
- [22] M. Dikaiakos, M. Kyriakou, G. Samaras, Performance evaluation of mobile-agent middleware: a hierarchical approach, in: G.P. Picco (Ed.), *Proceedings of the Fifth International Conference on Mobile Agents (MA 2001)*, Lecture Notes in Computer Science, vol. 2240, Springer, Berlin, 2001, pp. 244–259.
- [23] M. Dikaiakos, A. Stassopoulou, L. Papageorgiou, Characterizing crawler behavior from web server access logs, in: A. Min Tjoa, K. Bauknecht, G. Quirchmayr (Eds.), *Proceedings of the Fourth International Conference on Electronic Commerce and Web Technologies (EC-Web 2003)*, Lecture Notes in Computer Science Series, vol. 2738, Springer, Berlin, 2003, pp. 369–378.
- [24] M. Diligenti, F.M. Coetzee, C.L. Giles, M. Gori, Focused crawling using context graphs, in: *Proceedings of the 26th VLDB Conference*, 2000, pp. 527–534.
- [25] F. Dougliis, T. Ball, Y.-F. Chen, E. Koutsoufios, The AT&T internet difference engine: tracking and viewing changes on the web, *World Wide Web* 1 (1) (1998) 27–44.
- [26] P. Farjami, C. Gorg, F. Bell, Advanced service provisioning based on mobile agents, *Computer Communications* (23) (2000) 754–760.
- [27] A. Fox, I. Goldberg, S. Gribble, D. Lee, A. Polito, E. Brewer, Experience with top gun wingman: a proxy-based graphical web browser for the 3Com PalmPilot, in: *Proceedings of the IFIP International Conference on Distributed Systems Platforms and Open Distributed Processing (Middleware'98)*, 1998, pp. 407–426.
- [28] J. Gosling, B. Joy, G. Steele, *The Java Language Specification*, Addison-Wesley, Reading, MA, 1996.
- [29] S. Gribble, E. Brewer, J. Hellerstein, D. Culler, Scalable, distributed data structures for internet service construction, in: *Proceedings of the Fourth Symposium on Operating Systems Design and Implementation (OSDI 2000)*, The USENIX Association, 2000, pp. 319–332.
- [30] S. Gribble, M. Welsh, R. von Behren, E. Brewer, D. Culler, N. Borisov, S. Czerwinski, R. Gummadi, J. Hill, A. Joseph, R.H. Katz, Z.M. Mao, S. Ross, B. Zhao, The Ninja architecture for robust internet-scale systems and services, *Computer Networks* 35 (2001) 473–497.
- [31] J. Han, M. Kamber, *Data Mining: Concept and Techniques*, Morgan Kaufmann, Los Altos, CA, 2001.
- [32] A. Heydon, M. Najork, Mercator: a scalable, extensible web crawler, *World Wide Web* 2 (4) (1999) 219–229.
- [33] G. Huck, I. Macherius, P. Fankhauser, PDOM: lightweight persistence support for the document object model, in: *Proceedings of the 1999 OOPSLA Workshop Java and Databases: Persistence Options*. Held on the 14th Annual ACM SIGPLAN Conference on Object-Oriented Programming Systems, Languages, and Applications (OOPSLA'99), November, ACM, SIGPLAN, New York, 1999.
- [34] A. Joshi, On proxy agents, mobility, and web access, *Mobile Networks and Applications* 5 (2000) 233–241.
- [35] R. Koblick, Concordia, *Communications of the ACM* 42 (3) (1999) 96–99.
- [36] Horizon Systems Laboratory, *Mobile Agent Computing*, A White Paper, Mitsubishi Electric ITA, January 1998.
- [37] P. Maglio, R. Barrett, Intermediaries Personalize Information Streams, *Communications of the ACM* 43 (8) (2000) 96–101.
- [38] R. Miller, K. Bharat, SPHINX: a framework for creating personal, site-specific web crawlers, in: *Proceedings of the Seventh International WWW Conference*, April, 1998, pp. 161–172.
- [39] D. Milojevic, Internet technology, *IEEE Concurrency* January–March (2000) 70–81.
- [40] M. Najork, A. Heydon, High-Performance Web Crawling, Technical Report 173, Compaq Systems Research Center, September 2001.
- [41] GMD-IPSI XQL Engine, <http://xml.darmstadt.gmd.de/xql/>.
- [42] M. Perkowski, O. Etzioni, Towards adaptive web sites: conceptual framework and case study, *Artificial Intelligence* 118 (2000) 245–275.
- [43] S.H. Phatak, V. Esakki, B.R. Badrinath, L. Iftode, Web&: An Architecture for Non-Interactive Web, Technical Report DCS-TR-405, Department of Computer Science, Rutgers University, December 1999.
- [44] S. Raghavan, H. Garcia-Molina, Crawling the hidden web, in: *VLDB 2001: 27th International Conference on Very Large Data Bases*, September, 2001.
- [45] H. Rao, Y. Chen, D. Chang, M. Chen, iMobile: a proxy-based platform for mobile services, in: *The First ACM Workshop on Wireless Mobile Internet (WMI 2001)*, ACM, New York, 2001, pp. 3–10.
- [46] H. Rao, Y. Chen, M. Chen, A proxy-based web archiving service, in: *Middleware Symposium*, 2000.
- [47] G. Samaras, M. Dikaiakos, C. Spyrou, A. Liverdos, Mobile agent platforms for web-databases: a qualitative and quantitative assessment, in: *Proceedings of the Joint Symposium ASA/MA'99*. First International Symposium on Agent Systems and Applications (ASA'99), Third International Symposium on Mobile Agents (MA'99), October, IEEE Computer Society, Silver Spring, MD, 1999, pp. 50–64.
- [48] VMGEAR, OptimizeIt!: The Java Ultimate Performance Profiler, <http://www.vmgear.com/>.

- [49] T.W. Yan, H. Garcia-Molina, SIFT—a tool for wide-area information dissemination, in: Proceedings of the 1995 USENIX Technical Conference, 1995, pp. 177–186.
- [50] F. Yergeau, T. Bray, J. Paoli, C.M. Sperberg-McQueen, E. Maler, Extensible Markup Language (XML) 1.0 (Third Edition) W3C Recommendation, Technical Report REC-xml-20040204, World-Wide Web Consortium, February 2004, <http://www.w3.org/TR/2004/REC-xml-20040204/>.
- [51] D. Zeinalipour-Yazti, eRACE: an eXtensible Retrieval, Annotation and Caching Engine, BSc Thesis, June 2000 (In Greek).
- [52] D. Zeinalipour-Yazti, M. Dikaiakos, High-Performance Crawling and Filtering in Java, Technical Report TR-01-3, Department of Computer Science, University of Cyprus, June 2001.
- [53] D. Zeinalipour-Yazti, M. Dikaiakos, Design and implementation of a distributed crawler and filtering processor, in: A. Halevy, A. Gal (Eds.), Proceedings of the Fifth International Workshop on Next Generation Information Technologies and Systems (NGITS 2002), Lecture Notes in Computer Science, June, vol. 2382, Springer, Berlin, 2002, pp. 58–74.